

EOS NickelAlloy IN939
Material Data Sheet



EOS NickelAlloy IN939

Excellent High Temperature Performance with Corrosion Resistance

EOS NickelAlloy IN939 is a nickel-chromium alloy which provides an outstanding balance of high temperature strength, corrosion and oxidation resistance, fatigue performance and creep strength at temperatures up to 850 °C (1 560 °F). Parts built from EOS NickelAlloy IN939 can be hardened after manufacture by application of precipitation-hardening heat treatments.

Main Characteristics:

- Excellent mechanical properties
- Excellent corrosion and oxidation resistance
- High tensile, fatigue, creep and rupture strength at temperatures up to 850 °C (1 560 °F)
- Maintains good ductility in age-hardened condition
- Crack-free in as-built condition and resistant to strain-age cracking

Typical Applications:

- Industrial gas turbines (vanes, blades, heat-shields)
- Microturbines
- Turbochargers
- Instrumentation parts
- Power industry parts
- Process industry parts

The EOS Quality Triangle

EOS uses an approach that is unique in the AM industry, taking each of the three central technical elements of the production process into account: the system, the material and the process. The data resulting from each combination is assigned a Technology Readiness Level (TRL) which makes the expected performance and production capability of the solution transparent.

EOS incorporates these TRLs into the following two categories:

- Premium products (TRL 7-9): offer highly validated data, proven capability and reproducible part properties.
- Core products (TRL 3 and 5): enable early customer access to newest technology still under development and are therefore less mature with less data.

All of the data stated in this material data sheet is produced according to EOS Quality Management System and international standards.

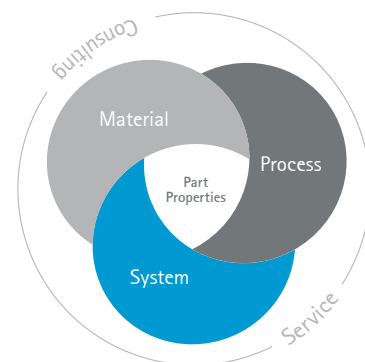

Powder Properties

EOS NickelAlloy IN939 has the following chemical composition.

Powder chemical composition (wt.-%)		Powder particle size	
Element	Typical	Generic particle size distribution	
Cr	22.5		20-55 μm
Co	19		
W	2.0		
Nb	1.0		
Ti	3.7		
Al	1.9		
Ta	1.4		
Zr	0.1		
C	0.15		
B	0.01		
Ni	Balance		

SEM micrograph of EOS NickelAlloy IN939 powder.

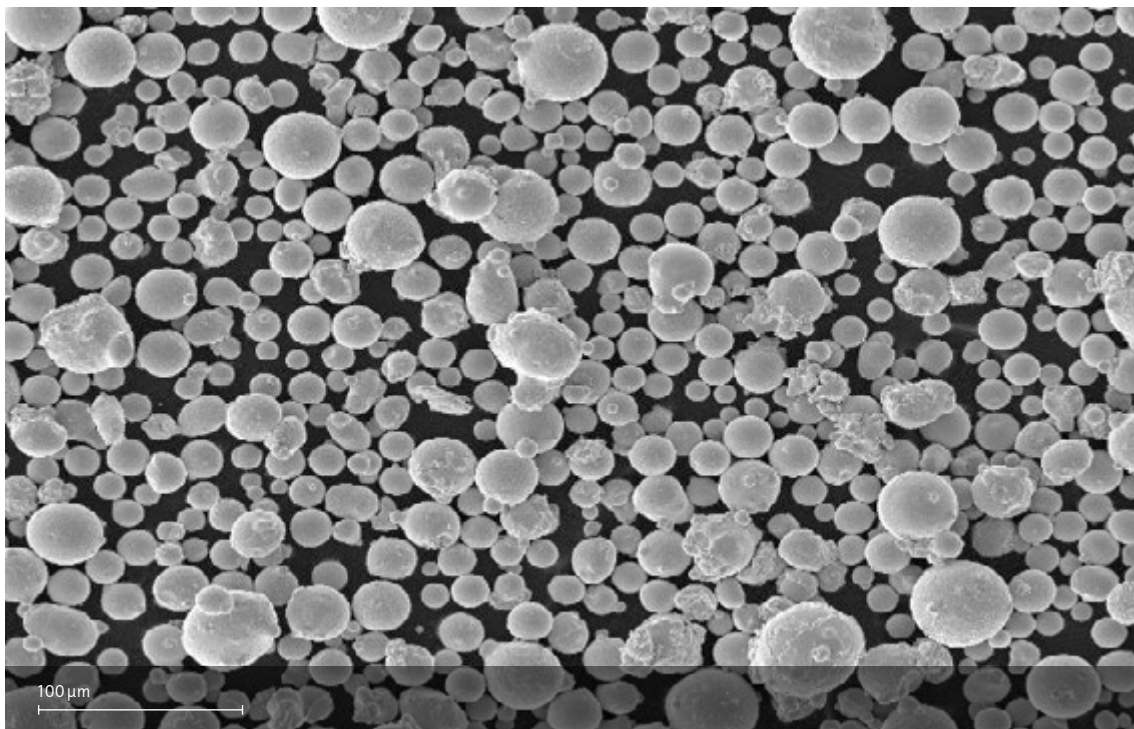

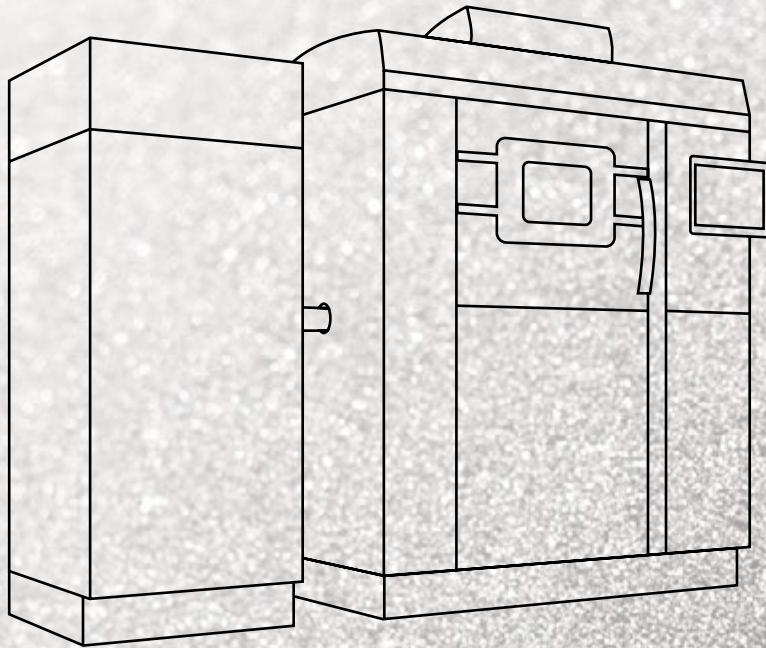

EOS NickelAlloy IN939 for EOS M 290 | 40 μm

Process Information
Heat Treatment
Physical Part Properties
Mechanical Properties
Additional Data

EOS NickelAlloy IN939 for EOS M 290 | 40 µm

Process Information

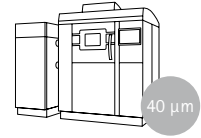

System set-up	EOS M 290
EOS MaterialSet	IN939_040_HiPerM291_100
Software requirements	EOSPRINT 2.6 or newer EOSYSTEM 2.10 or newer
Powder part no.	9011-0030
Recoater blade	EOS HSS Blade
Nozzle	EOS Grid Nozzle
Inert gas	Argon
Sieve	63 µm

Additional information

Layer thickness	40 µm
Volume rate	3.6 mm ³ /s
Min. wall thickness	Typical 0.3 - 0.4 mm

Heat Treatment

The as-built microstructure of additively-manufactured IN939 consists of gamma phase (γ) and primary carbides. Heat treatment is required for the material to reach the desired microstructure and part properties through precipitation of the gamma prime (γ') strengthening phase. EOS has developed a short, AM-optimized 3-step heat treatment (14 hours at temperature), which results in similar or better properties than the commonly used 4-step heat treatment (50 hours at temperature). The gamma prime (γ') volume fraction after heat-treatment is in the range of 30 to 40 %.

Solution treatment:

Step 1: The purpose of this treatment is to homogenize the gamma matrix: Hold at 1190 °C for 4 hours followed by fast air / argon cooling.

Aging treatment:

The purpose of aging steps is the precipitation and growth of gamma prime (γ') and carbides.

Step 2: Hold at 1000 °C for 6 hours, followed by fast air / argon cooling.

Step 3: Hold at 800 °C for 4 hours, followed by cooling in still air / argon.

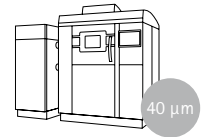

Chemical and Physical Properties of Parts

Chemical composition of built parts is compliant to EOS NickelAlloy IN939 powder chemical composition.

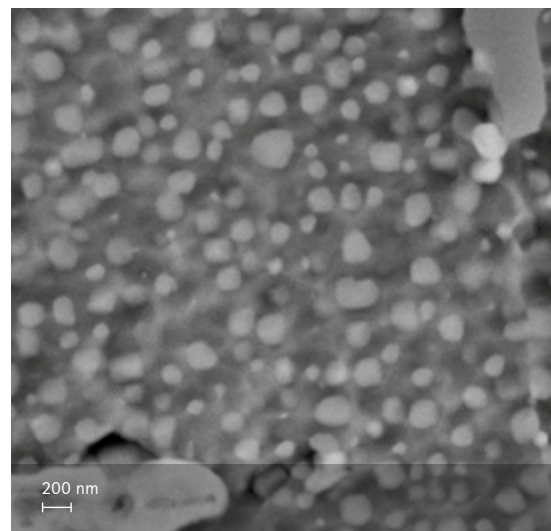
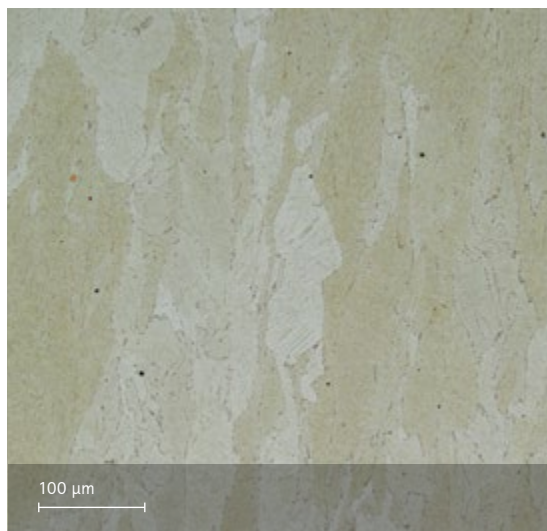

Images show the microstructure of the alloy at two magnifications.

The image on the left shows the grain structure, while the image on the right shows the strengthening phases (gamma prime) at a much higher magnification.

Defects	Result	Number of samples
Average defect percentage	0.01 %	50
Density ISO3369	Result	Number of samples
Average density	min 8.15 g/cm ³	NA

The areal defect percentage was determined from cross-sections of built parts using an optical microscope fitted with a camera and analysis software. The analysis was carried out for a sample area of 15 x 15 mm². The defects were detected and analyzed with an image capture/analysis software with an automatic histogram based filtering procedure on monochrome images.

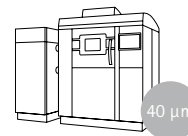

Mechanical Properties in Heat Treated Condition

Tensile properties ISO 6892-1

Room temperature

	Yield strength $R_{p0.2}$ [MPa]	Ultimate tensile strength R_m [MPa]	Elongation at break A [%]	Number of samples
Vertical	1 100	1 500	13	187
Horizontal	1 130	1 520	11	160

Hardness at room temperature ISO 6508

Hardness, HRC	48
Number of samples	10

Validation with three powder lots and three EOS M 290 systems. Data presented with tolerance interval limits that 90% of the population fulfill with 95% level of confidence.

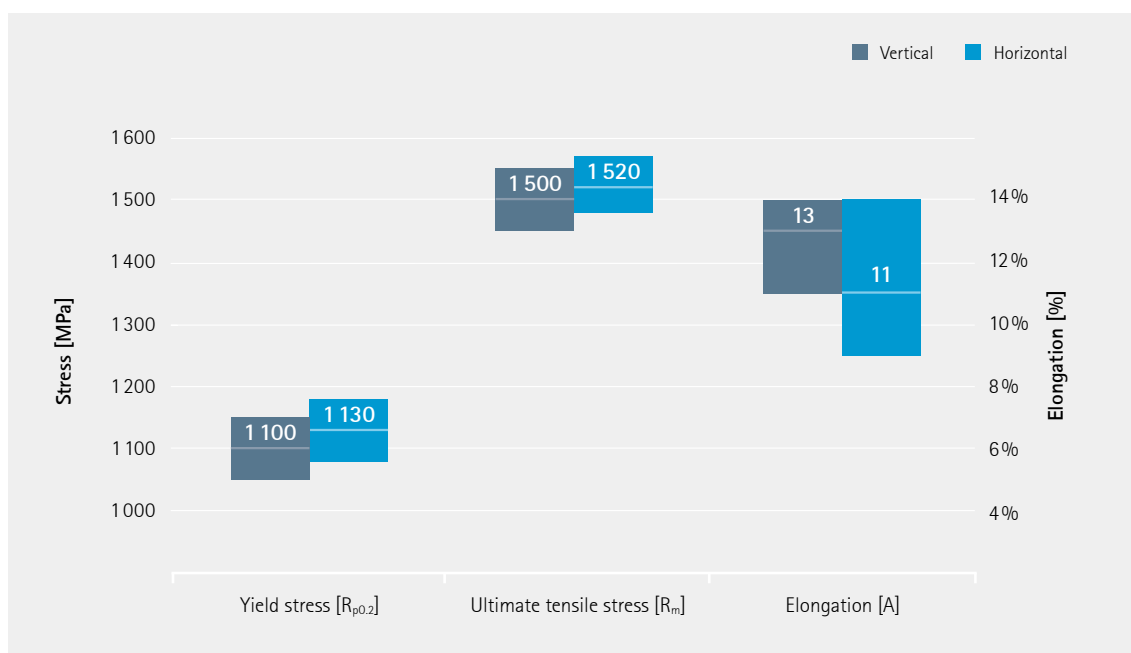

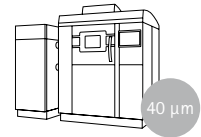

Tensile Properties ISO 6892-2 at Elevated Temperature in Heat Treated Condition

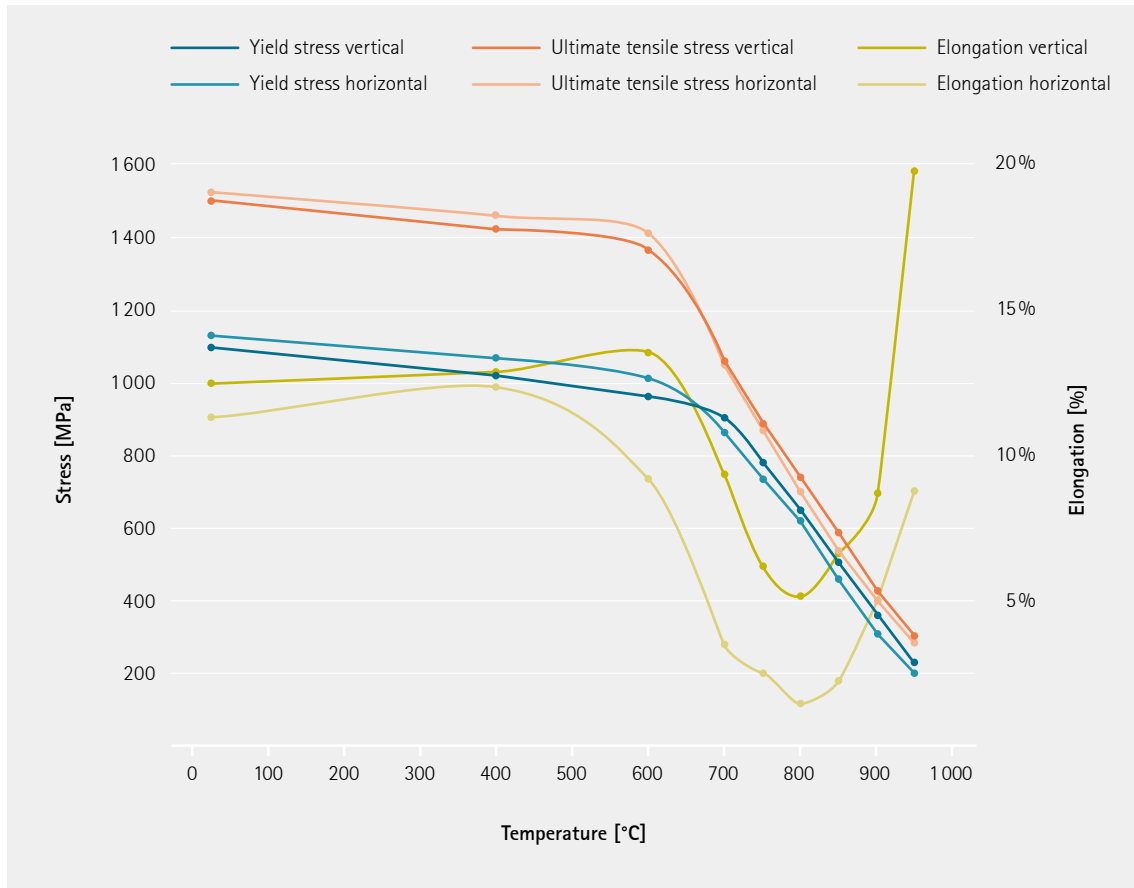

Mechanical Properties As-Manufactured

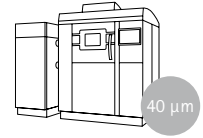

Tensile properties as manufactured ISO 6892-1

	Yield strength $R_{p0.2}$ [MPa]	Ultimate tensile strength R_m [MPa]	Elongation at break A [%]	Number of samples
Vertical	740	1 090	28	21
Horizontal	880	1 160	24	18

Hardness as manufactured ISO 6508

Hardness, HRC	33
Number of samples	10

Data collected on a standard validation job with one powder lot and one EOS M 290 system. Data presented with tolerance interval limits that 90 % of the population fulfill with 95 % level of confidence.

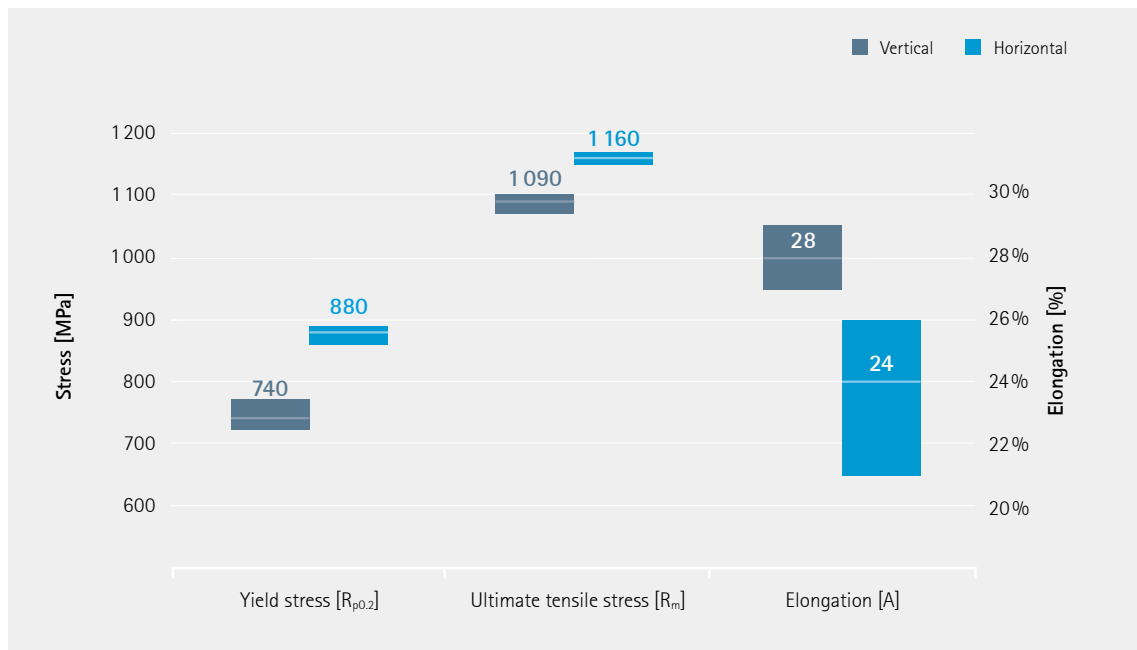

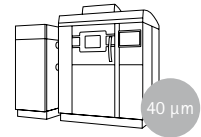

Additional Data

Low Cycle Fatigue

Low cycle fatigue performance of horizontally and vertically oriented samples at temperatures of 25 °C, 650 °C, 750 °C and 850 °C. The data represents cycles to failure for different strain amplitudes. No HIP was applied.

Method, standard, cycles: axial, strain controlled testing according to ASTM E606

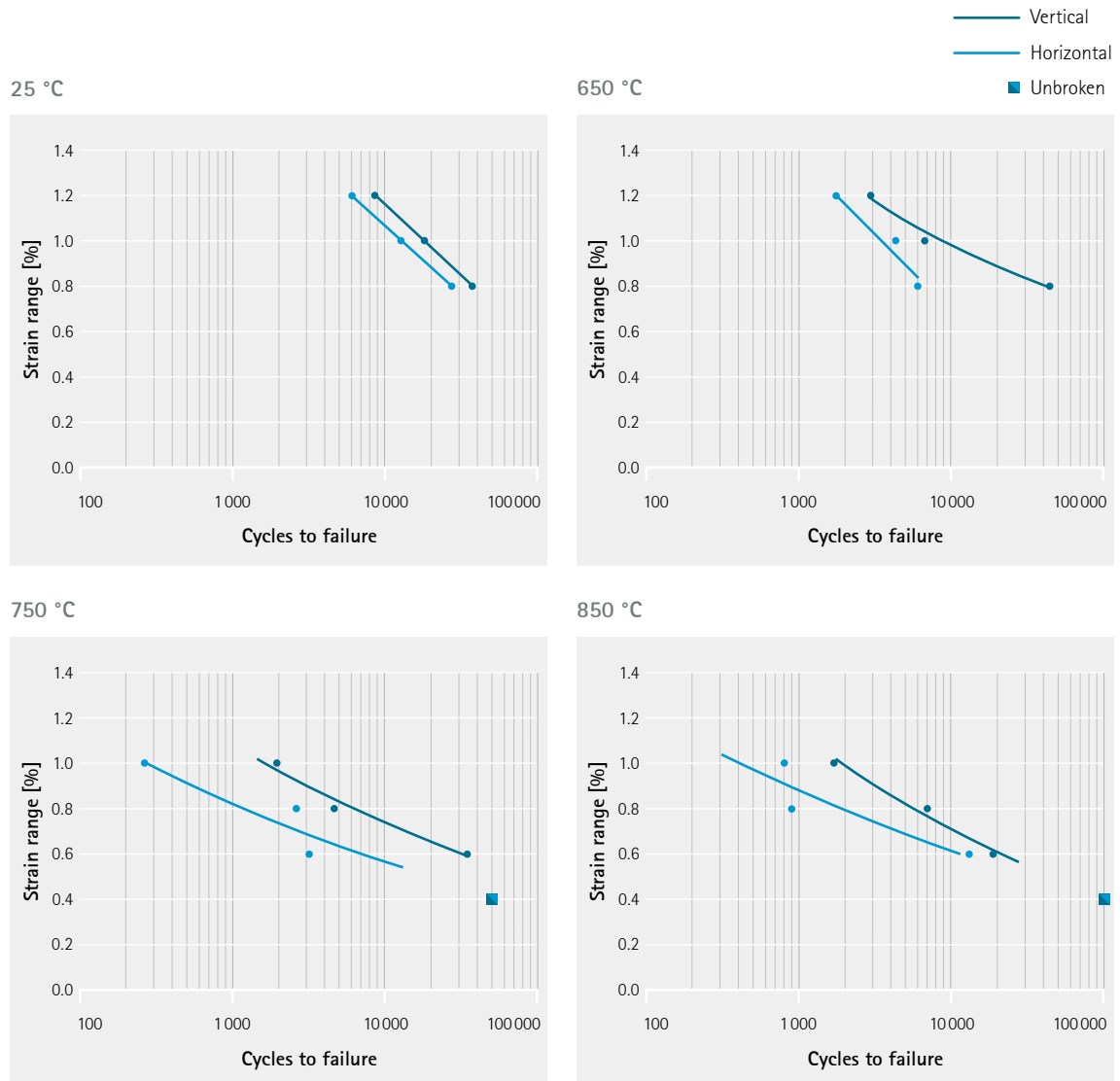

Additional Data

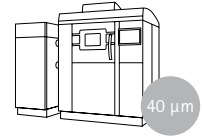

Creep Performance

The stress-rupture performance of EOS NickelAlloy IN939 was tested on vertically oriented samples, in heat-treated condition. No HIP was applied. The data presents the Larson-Miller Parameter values achieved at stress levels of 100 MPa, 250 MPa and 450 MPa. Standard: ASTM E139

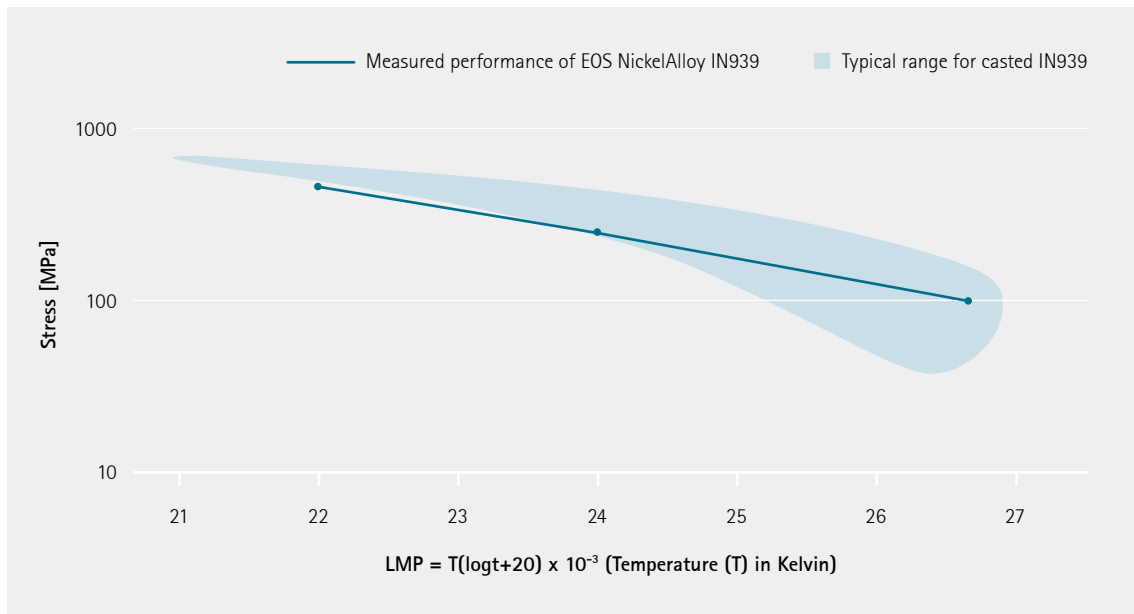

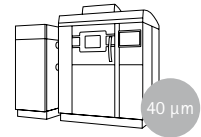

Additional Data

Coefficient of Thermal Expansion (as manufactured) ASTM E228

Temperature	25 – 100 °C	25 – 200 °C	25 – 400 °C	25 – 600 °C	25 – 800 °C	25 – 900 °C
CTE	$12.18 \cdot 10^{-6}/K$	$12.89 \cdot 10^{-6}/K$	$13.78 \cdot 10^{-6}/K$	$13.49 \cdot 10^{-6}/K$	$13.99 \cdot 10^{-6}/K$	$15.06 \cdot 10^{-6}/K$

Coefficient of Thermal Expansion (heat treated) ASTM E228

Temperature	25 – 100 °C	25 – 200 °C	25 – 400 °C	25 – 600 °C	25 – 800 °C	25 – 900 °C
CTE	$11.79 \cdot 10^{-6}/K$	$12.64 \cdot 10^{-6}/K$	$13.64 \cdot 10^{-6}/K$	$14.27 \cdot 10^{-6}/K$	$15.29 \cdot 10^{-6}/K$	$16.32 \cdot 10^{-6}/K$

Surface Roughness of Downskin (as manufactured)

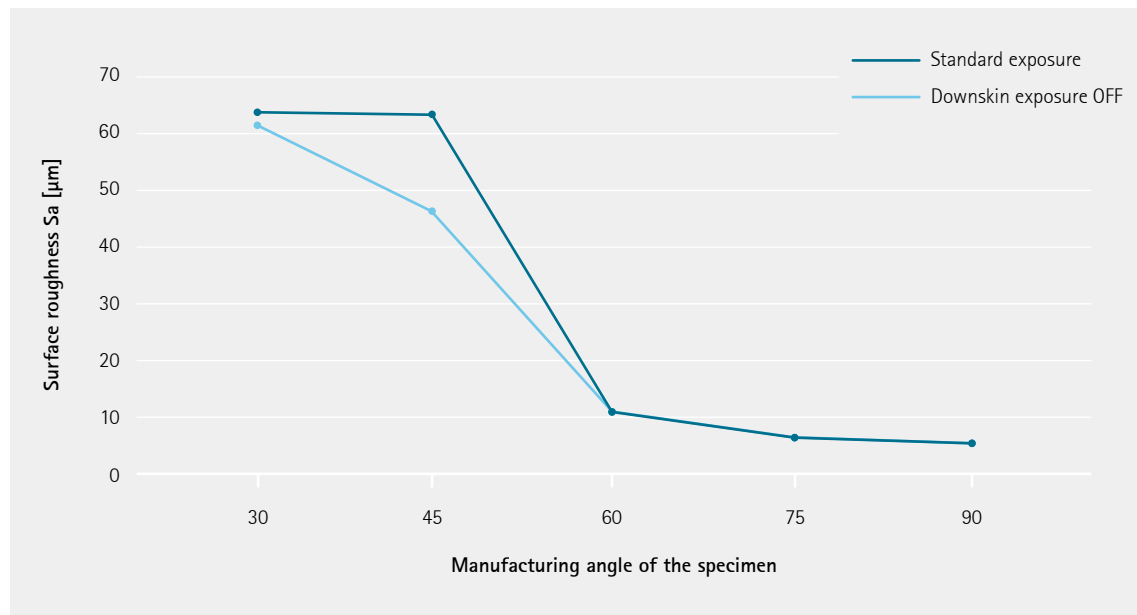

EOS NickelAlloy IN939 parameters were developed for optimized dimensional accuracy of internal cooling features, which are essential to hot gas path components in gas turbines. This comes with a compromise on downskin roughness. Whenever possible, for parts where optimized dimensional accuracy of internal cooling features is not needed, EOS recommends to switch off downskin exposure, to improve downskin roughness and buildability at low angles, and to increase process speed.

The surface quality was characterized by optical measurement method according to internal procedure. The 90 degree angle corresponds to vertical surface.

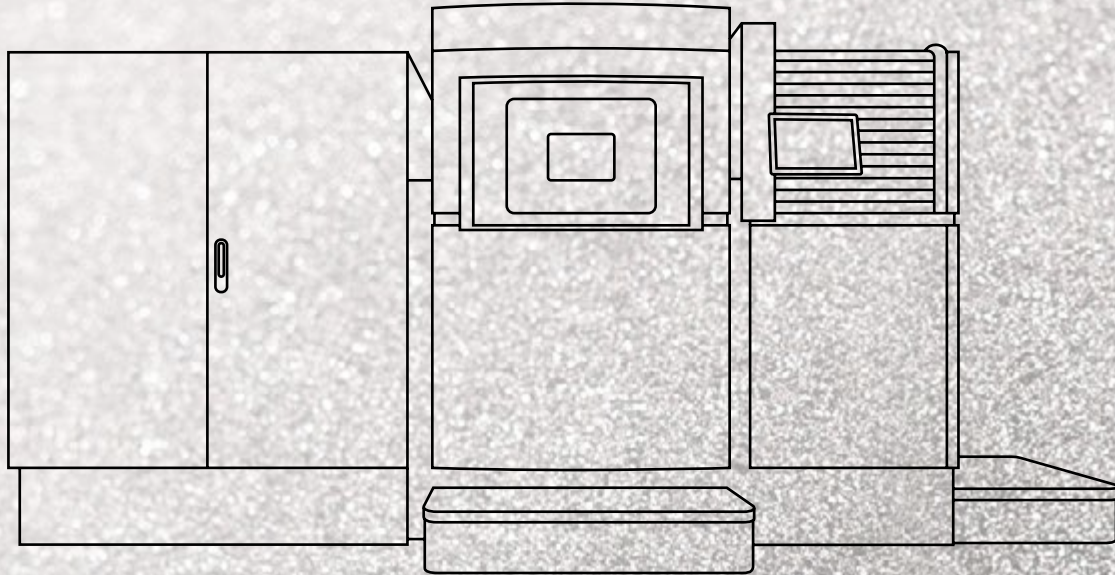

EOS NickelAlloy IN939 for EOS M 400-4 | 40 μm

Process Information
Heat Treatment
Physical Part Properties
Mechanical Properties
Additional Data

EOS NickelAlloy IN939 for EOS M 400-4 | 40 µm Process Information

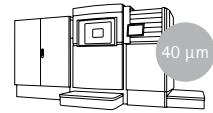

This process parameter includes two variations of the exposure set: the first one provides better productivity and overhang buildability, while the second one is designed for optimized internal feature and cooling channel accuracy.

System set-up		EOS M 400-4
EOS MaterialSet		IN939_040_CoreM404_100
Software requirements		EOSPRINT 2.8 or newer EOSYSTEM 2.12 or newer
Powder part no.		9011-0030
Recoater blade		EOS HSS Blade
Inert gas		Argon
Sieve		63 µm

Additional information

Layer thickness	40 µm
Volume rate	4 x 3.6 mm ³ /s
Min. wall thickness	Typical 0.3 - 0.4 mm

Heat Treatment

The as-built microstructure of additively-manufactured IN939 consists of gamma phase (γ) and primary carbides. Heat treatment is required for the material to reach the desired microstructure and part properties through precipitation of the gamma prime (γ') strengthening phase. EOS has developed a short, AM-optimized 3-step heat treatment (14 hours at temperature), which results in similar or better properties than the commonly used 4-step heat treatment (50 hours at temperature). The gamma prime (γ') volume fraction after heat-treatment is in the range of 30 to 40 %.

Solution treatment:

Step 1: The purpose of this treatment is to homogenize the gamma matrix: Hold at 1190 °C for 4 hours followed by fast air / argon cooling.

Aging treatment:

The purpose of aging steps is the precipitation and growth of gamma prime (γ') and carbides.

Step 2: Hold at 1000 °C for 6 hours, followed by fast air / argon cooling.

Step 3: Hold at 800 °C for 4 hours, followed by cooling in still air / argon.

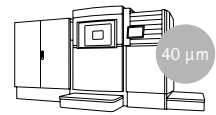

Chemical and Physical Properties of Parts

Chemical composition of built parts is compliant to EOS NickelAlloy IN939 powder chemical composition.

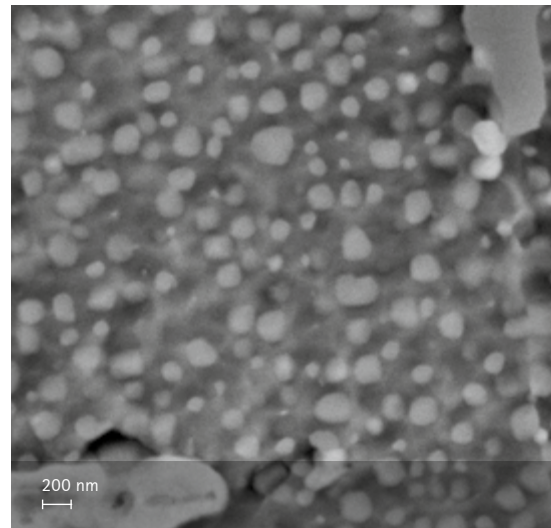
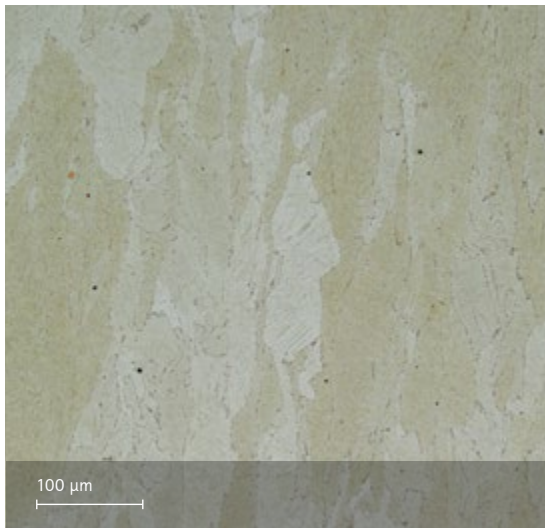

Images show the microstructure of the alloy at two magnifications.

The image on the left shows the grain structure, while the image on the right shows the strengthening phases (gamma prime) at a much higher magnification.

Defects	Result	Number of samples
Average defect percentage	0.01 %	10
Density ISO3369	Result	Number of samples
Average density	min 8.15 g/cm ³	NA

The areal defect percentage was determined from cross-sections of built parts using an optical microscope fitted with a camera and analysis software. The analysis was carried out for a sample area of 15 x 15 mm². The defects were detected and analyzed with an image capture/analysis software with an automatic histogram based filtering procedure on monochrome images.

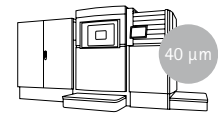

Mechanical Properties

Tensile properties as manufactured ISO 6892-1

	Yield strength $R_{p0.2}$ [MPa]	Ultimate tensile strength R_m [MPa]	Elongation at break A [%]	Number of samples
Vertical	740	1 090	28	21
Horizontal	880	1 160	24	18

Tensile properties heat treated ISO 6892-1

Room temperature

	Yield strength $R_{p0.2}$ [MPa]	Ultimate tensile strength R_m [MPa]	Elongation at break A [%]	Number of samples
Vertical	1 080	1 460	11	34
Horizontal	1 160	1 560	9.5	28

Tensile Properties ISO 6892-2 at Elevated Temperature in Heat Treated Condition

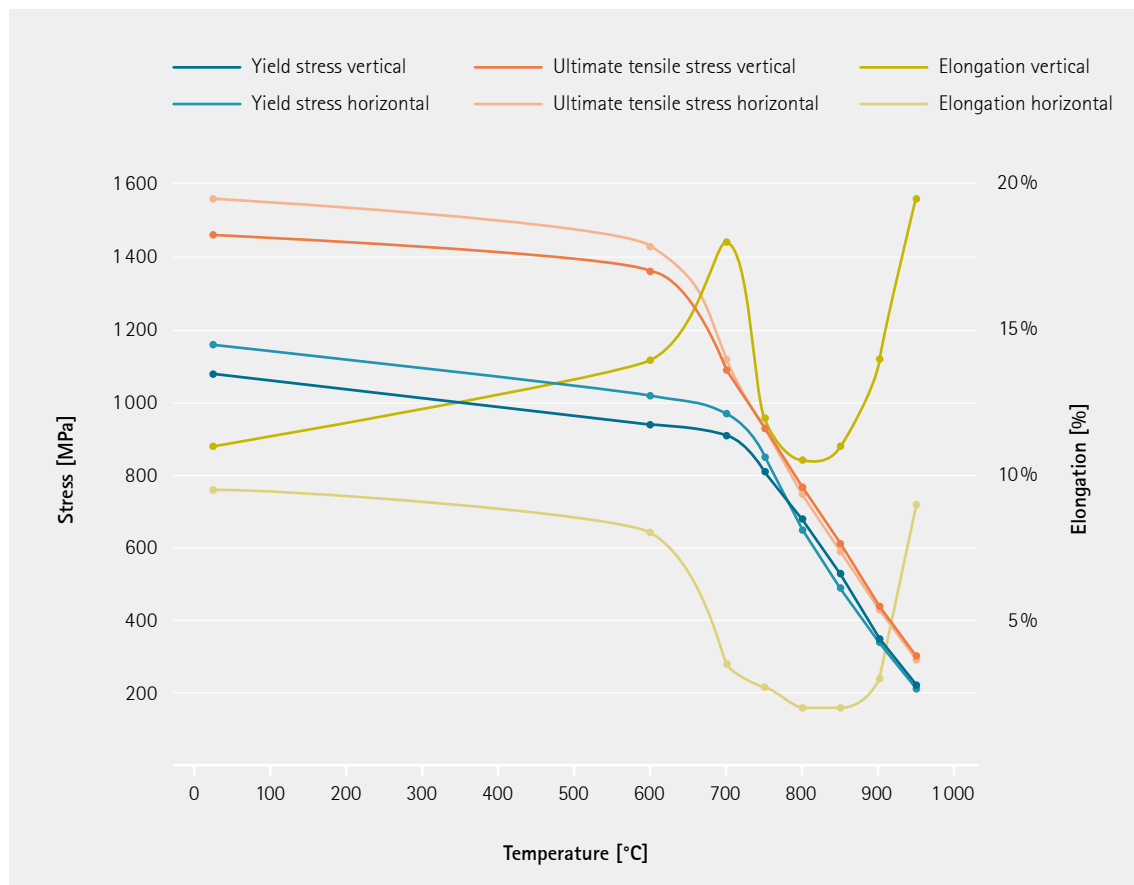

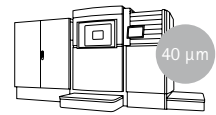

Additional Data

Creep Performance

The stress-rupture performance of EOS NickelAlloy IN939 was tested on vertically oriented samples, in heat-treated condition. No HIP was applied. The data presents the Larson-Miller Parameter values achieved at stress levels of 100 MPa, 250 MPa and 450 MPa. Standard: ASTM E139

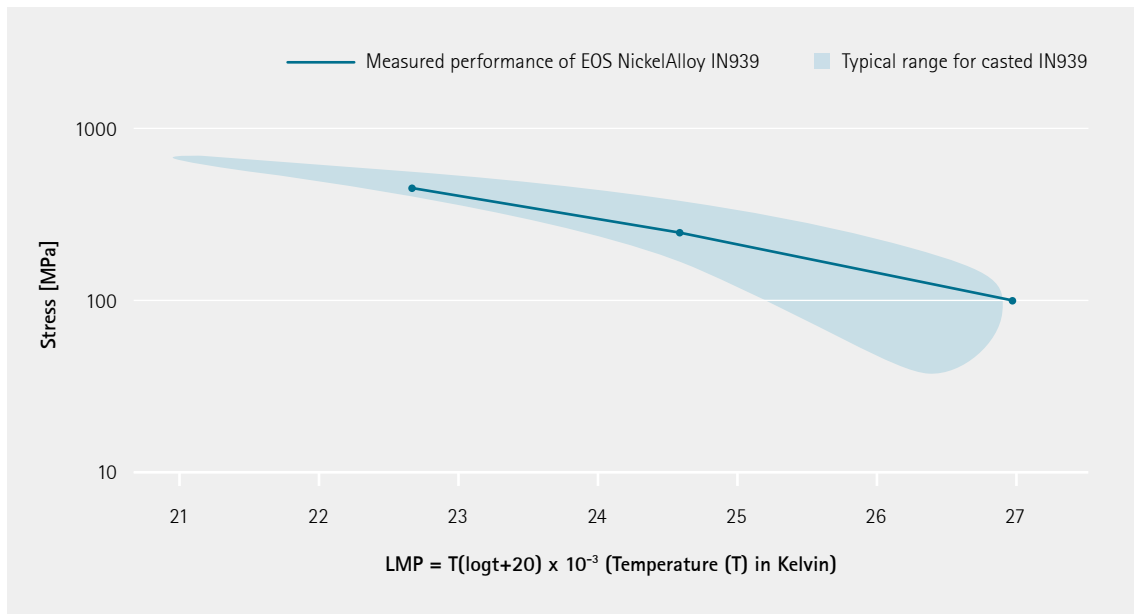

Additional Data

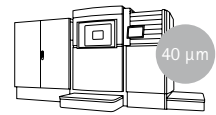

Surface Roughness of Downskin (as manufactured)

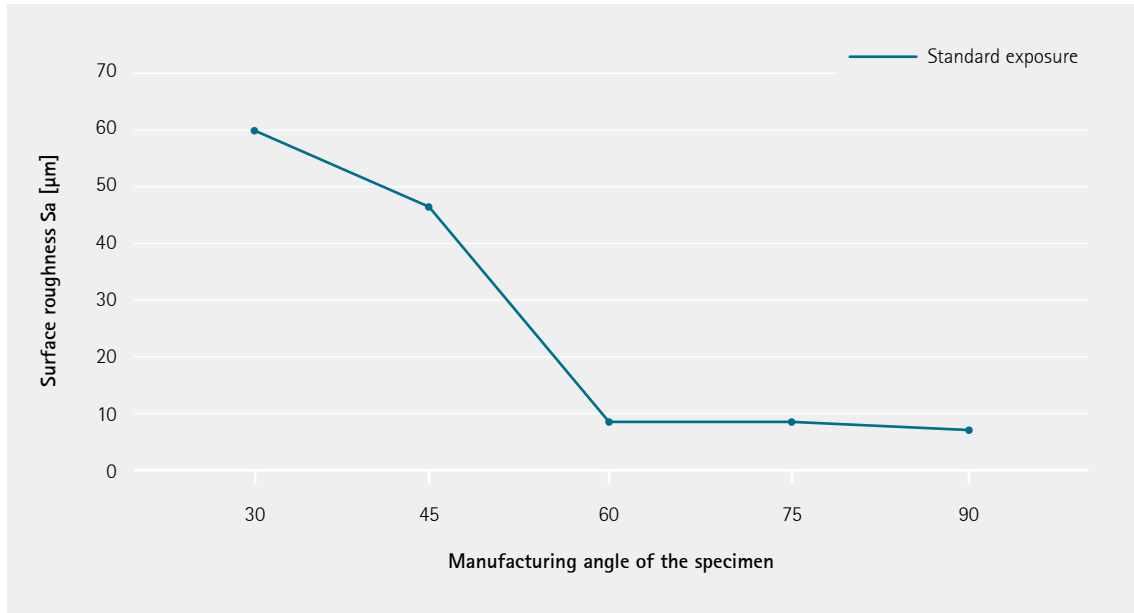

The surface quality was characterized by optical measurement method according to internal procedure. The 90 degree angle corresponds to vertical surface.

Headquarters

EOS GmbH
Electro Optical Systems
Robert-Stirling-Ring 1
D-82152 Krailling/Munich
Germany
Phone +49 89 893 36-0
info@eos.info

www.eos.info

in EOS

 EOSGmbH

 EOS.global

 EOSGmbH

#ShapingFuture

Further Offices

EOS France
Phone +33 437 497 676

EOS Greater China
Phone +86 21 602 307 00

EOS India
Phone +91 443 964 8000

EOS Italy
Phone +39 023 340 1659

EOS Japan
Phone +81 45 670 0250

EOS Korea
Phone +82 2 6330 5800

EOS Nordic & Baltic
Phone +46 31 760 4640

EOS North America
Phone +1 877 388 7916

EOS Singapore
Phone +65 6430 0463

EOS UK
Phone +44 1926 675 110

05/2022

EOS is certified according to ISO 9001. EOS®, DMLS®, EOSPRINT® and EOSTATE® are registered trademarks of EOS GmbH in some countries. For more information visit www.eos.info/trademarks.

Cover: This image shows a possible application.

The quoted values refer to the use of this material with above specified type of EOS DMLS system, EOSYSTEM and EOSPRINT software version, parameter set and operation in compliance with parameter sheet and operating instructions. Part properties are measured with specified measurement methods using defined test geometries and procedures. Further details of the test procedures used by EOS are available on request. Any deviation from these standard settings may affect the measured properties. The data correspond to EOS knowledge and experience at the time of publication and they are subject to change without notice as part of EOS' continuous development and improvement processes. EOS does not warrant any properties or fitness for a specific purpose, unless explicitly agreed upon. This also applies regarding any rights of protection as well as laws and regulations.

